

Зип Общепит

DESPIECE TECNICO

vsezip.ru

+7(812)987-08-81

**Freidoras  
Deep Fat Fryers  
Friteuses  
Friteusen  
Friggitrici**

**GAMA 900**

**Modelos:**

**FG9-05**

**FG9-10**

**FG9-05 S**

**FE9-05**

**FE9-10**

**FE9-05 S**

*Junio 2006 June*



**Fagor Industrial**

ЗипОбщепит

vsezip.ru

+7(812)987-08-81

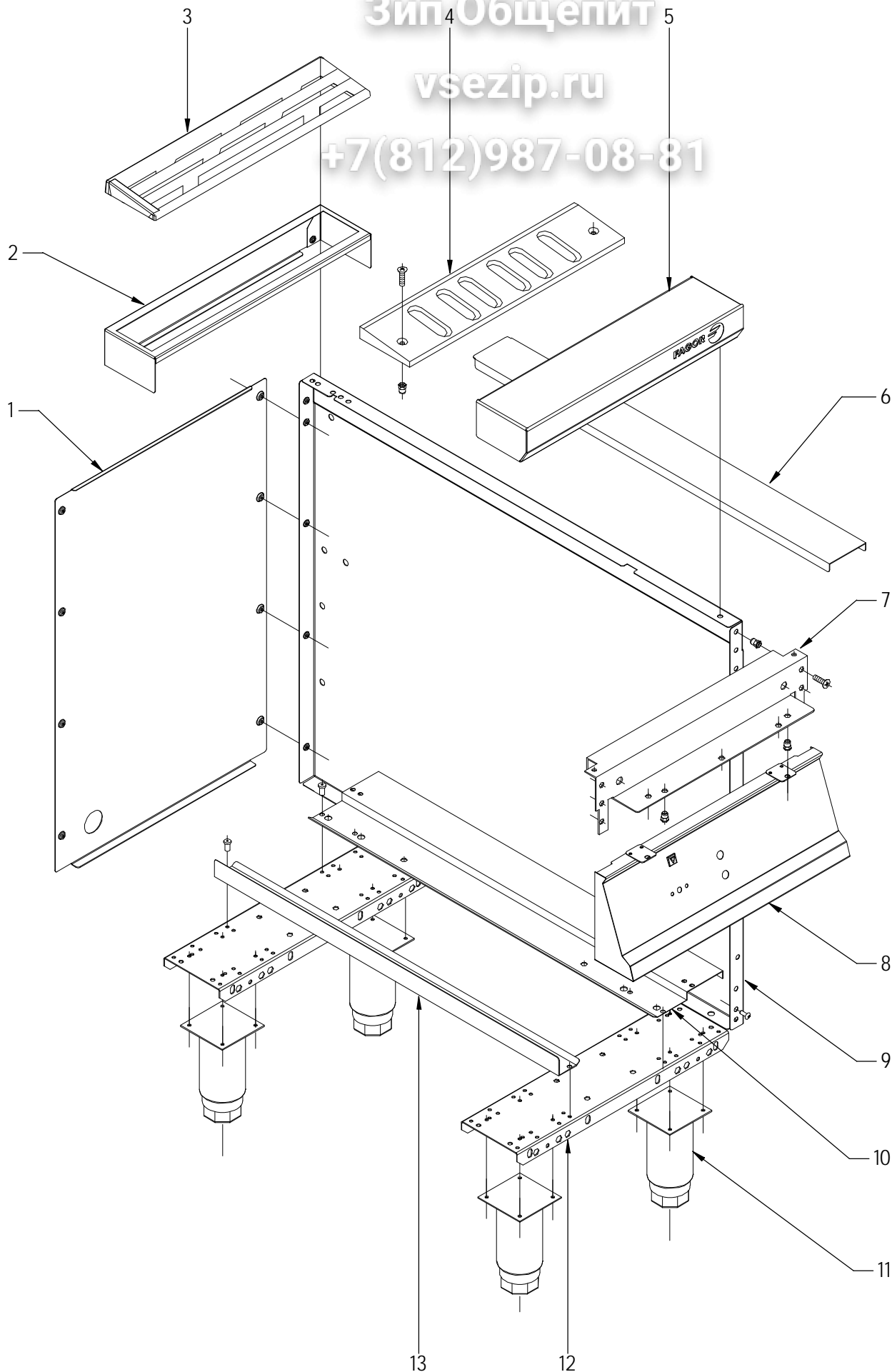

N plano	Firma	Fecha	Aparato	MUEBLE	Lamina	Fagor Industrial S.Coop. <b>FAGOR</b>
C-1716	<i>[Signature]</i>	2006-06	FREIDORA GAMA 900		1	Onate

# Зип Общепит

vsezip.ru

ZONA

MUEBLE

MOD.		FREIDORAS					
ITEM	CODIGO	DENOMINACION	TEXTO	FG9-05	FG9-10	FE9-05	FE9-10
1	X162812000	PANEL POSTERIOR 1/2M		1	-	1	-
1	X172803000	PANEL POSTERIOR 1M		-	1	-	1
	Q419005000	REMACHE 4x8 ALMG3 / ALUMINIO		8	12	8	12
	Q221342000	REMACHE EXAGONAL M5		-	-	4	8
2	R205429000	SOPORTE EMBELLECEDOR 1/2M		1	2	1	2
	Q419005000	REMACHE 4x8 ALMG3 / ALUMINIO		2	2	2	2
3	R205425000	EMBELLECEDOR ESMALTE		1	2	-	-
4	R205426000	EMBELLECEDOR ESMALTE ELEC.		-	-	1	2
5	X505401000	ANTERIOR MESA 1/2M		1	-	1	-
5	U025401000	ANTERIOR MESA 1M		-	1	-	1
	Q152004000	TORN.APLASTADO M5x13 A 304		2	2	2	2
	Q302022000	ARANDELA 16x6x1.2 A.304		2	2	2	2
6	X176100000	UNION DE MODULOS		-	1	-	1
7	X502666000	ESCUADRA AMARRE ANTERI.1/2M		1	-	1	-
7	U022601000	ESCUADRA AMARRE ANTERI.1M		-	1	-	1
	Q221342000	REMACHE EXAGONAL M5		3	3	3	3
	Q152004000	TORN. APLASTADO M5x13 A304		6	12	6	12
	Q302022000	ARANDELA 16x6x1.2 A.304		1	1	1	1
	Q162040000	TUERCA EXAGONAL M6		2	4	2	4
8	X502805000	PORTAM. COMP. FREIDORA 1/2M		1	-	1	-
8	X702801000	PORTAM. COMP. FREIDORA 1M		-	1	-	1
	Q152004000	TORN. APLASTADO M5x13 A 304		2	2	2	2
	Q563004000	LENGÜETA COMPONENTES		1	1	1	1
	Q523000000	TERMINAL LENGÜETA 6,35		1	1	-	-
	Q419005000	REMACHE 4x8 ALMG3 / ALUMINIO		1	1	1	1
9	X162811000	PANEL LATERAL DERECHO G900		1	2	1	2
S/N	X162810000	PANEL LATERAL IZQUIERDO G900		1	2	1	2
	Q221343000	REMACHE EXAGONAL M6		8	16	8	16
	Q221342000	REMACHE EXAGONAL M5		4	8	4	8
	Q221342000	REMACHE EXAGONAL M5		6	12	6	12

# Зип Общепит

vsezip.ru

+7(812)987-08-81

MOD.		FREIDORAS		ZONA	MUEBLE			
ITEM	CODIGO	DENOMINACION	TEXTO	FG9-05	FG9-10	FE9-05	FE9-10	
10	X162635000	CHAPA GUIA TAPA		1	2	1	2	
	Q411304000	REMACHE AVIBULBO Ø4,8		4	8	4	8	
11	X260151000	PATA REGULABLE		4	4	4	4	
	Q411304000	REMACHE AVIBULB. Ø4,8		14	14	14	14	
	Q411304000	REMACHE AVIBULB. Ø4,8		2	2	2	2	
	Q012042000	TORNILLO EXAGONAL M6x15		8	8	8	8	
	Q302022000	ARANDELA 16x6x1.2 A.304		1	1	1	1	
12	R212650000	LISTON SOPORTE PATAS 1/2M		2	-	2	-	
12	X172630000	LISTON SOPORTE PATAS 1M		-	2	-	2	
	Q232040000	ARANDELA A6		10	10	10	10	
13	X162636000	ESCUADRA GUIA BACINETA		1	2	1	2	
	Q411304000	REMACHE AVIBULBO Ø4,8		4	8	4	8	

Зип Общепит

vsezip.ru

+7(812)987-08-81

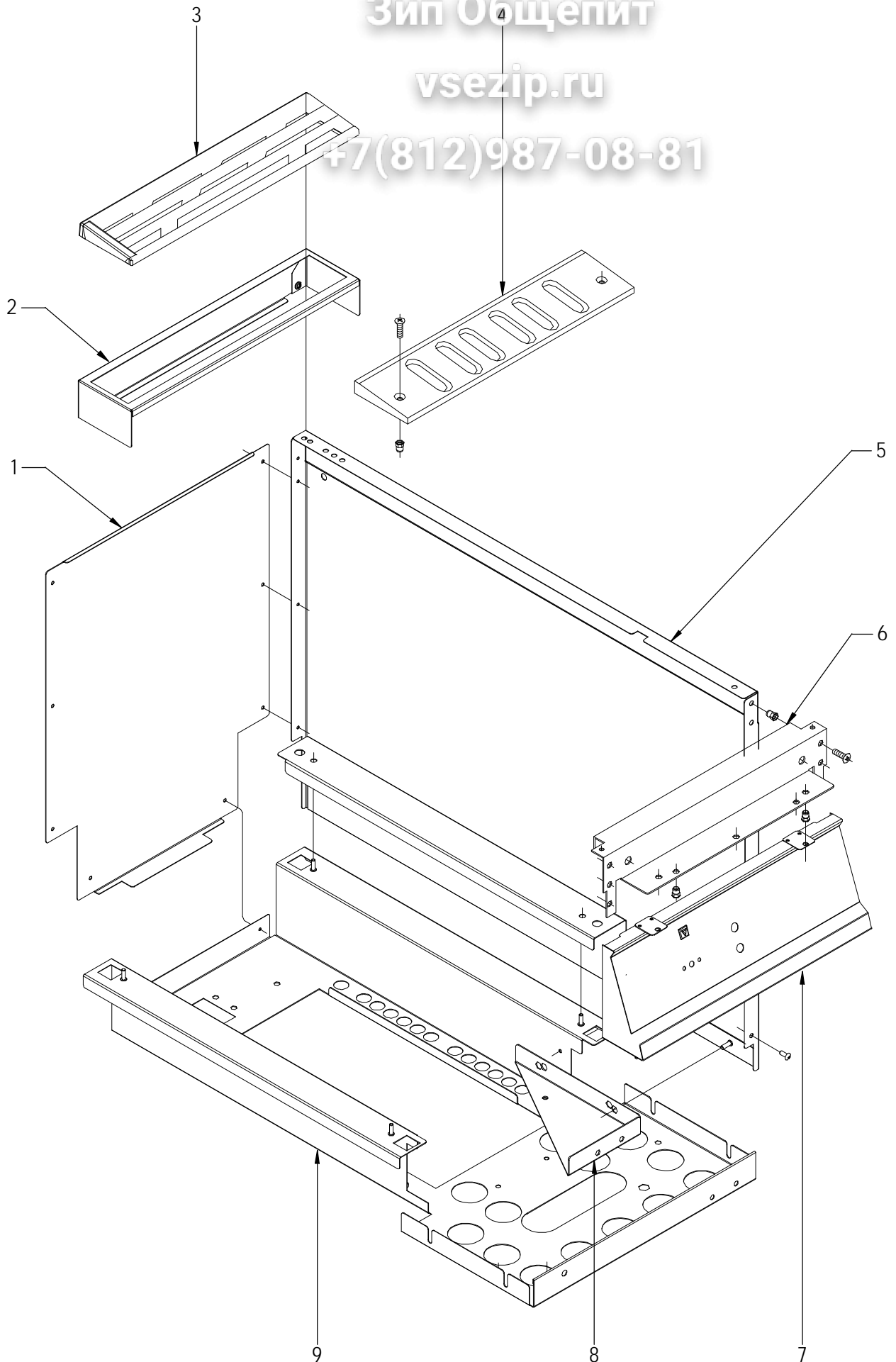

N plano

Firma

Fecha

Aparato

MUEBLE

Lamina

Fagor Industrial S.Coop.



C-1717

*name (signature)*

2006-05

FREIDORA GAMA 900(SUSPEN.)

2

Onate

# Зип Общепит

vsezip.ru

+7(812)987-08-81

MOD.		FREIDORAS (SUSPENDIDAS)	ZONA	MUEBLE			
ITEM	CODIGO	DENOMINACION	TEXTO	FG9-05 S	FE9-05 S		
1	X192807000	PANEL POSTERIOR 1/2M		1	1		
	Q419005000	REMACHE 4x8 ALMG3 / ALUMINIO		6	6		
2	R205429000	SOPORTE EMBELLECEDOR 1/2M		1	1		
3	R205425000	EMBELLECEDOR ESMALTE		1			
4	R205426000	EMBELLECEDOR ESMALTE ELEC.			1		
5	X192805000	PANEL LATERAL DERECHO G900		1	1		
S/N	X192803000	PANEL LATERAL IZQUIERDO G900		1	1		
	Q221342000	REMACHE EXAGONAL M5		4	4		
	Q221342000	REMACHE EXAGONAL M5		6	6		
	Q221345000	REMACHE EXAGONAL M10		4	4		
6	X502666000	ESCUADRA AMARRE ANTERI.1/2M		1	1		
	Q221342000	REMACHE EXAGONAL M5		3	3		
	Q152004000	TORN. APLASTADO M5x13 A304		6	6		
	Q302022000	ARANDELA 16x6x1.2 A.304		1	1		
	Q162040000	TUERCA EXAGONAL M6		2	2		
7	X502805000	PORTAMANDOS FREIDORA 1/2M		1	1		
	Q152004000	TORN. APLASTADO M5x13 A 304		2	2		
	Q563004000	LENGÜETA COMPONENTES		1	1		
	Q523000000	TERMINAL LENGÜETA 6,35			1		
	Q419005000	REMACHE 4x8 ALMG3 / ALUMINIO		1	1		
8	X192605000	REFUERZO BASE INFERIOR SUS.		1	1		
	Q012041000	TORNILLO EXAGONAL M6x10 A304		2	2		
	Q302022000	ARANDELA 16x6x1.2 A.304		1	1		
	Q221342000	REMACHE EXAGONAL M5		2	2		
	Q072035000	TORNILLO GOTA DE SEBO M5x30		2	2		
9	X192808000	BASE INFERERIOR COMPLETA		1	1		
	Q221343000	REMACHE EXAGONAL M6		2	2		

Зип Общепит

vsezip.ru

+7(812)987-08-81

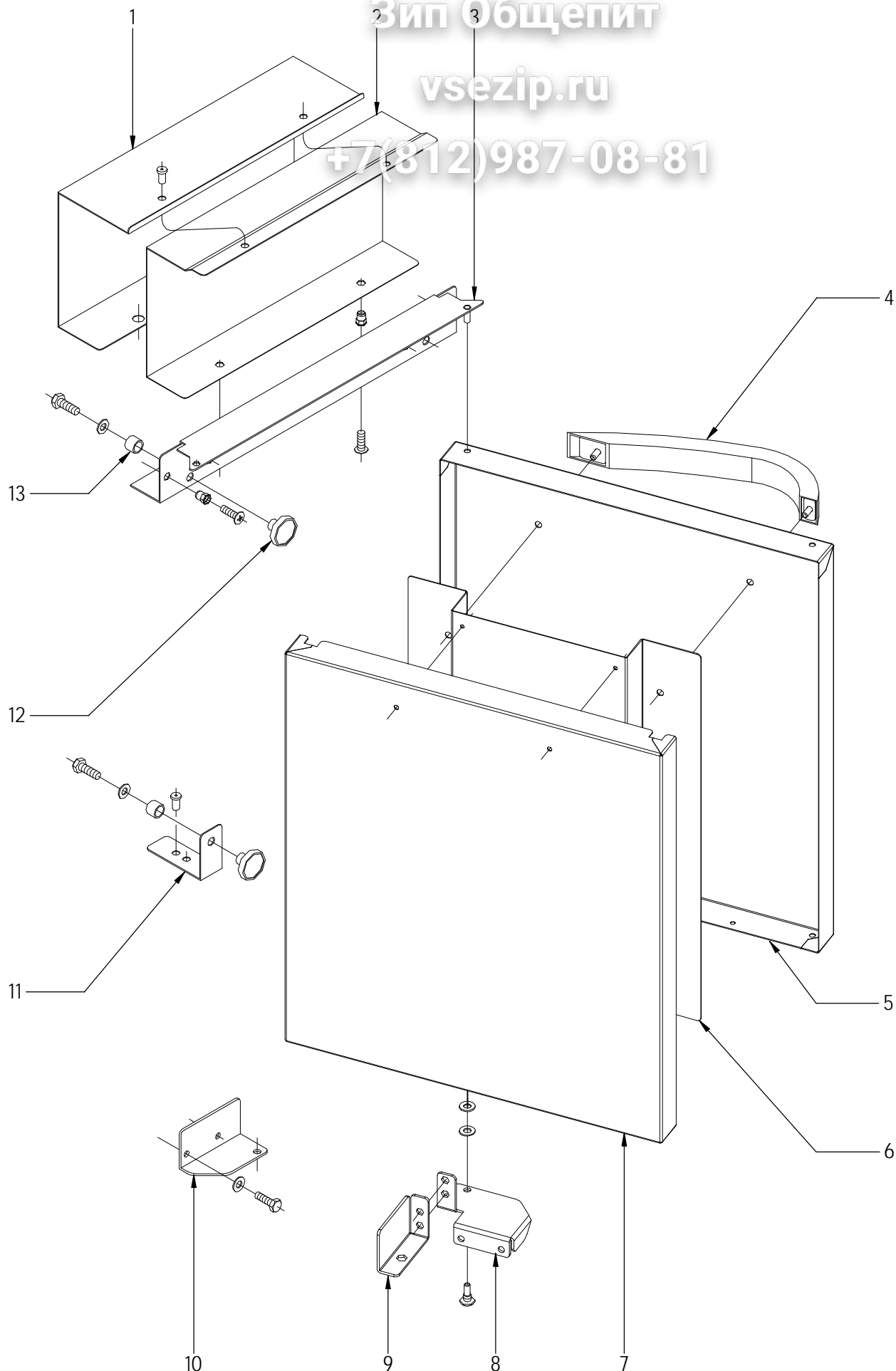

N plano	Firma	Fecha	Aparato	PUERTAS	Lamina	Fagor Industrial S.Coop. <b>FAGOR</b>
C-1718	<i>[Signature]</i>	2006-06	FREIDORA GAMA 900		3	Onate

# Зип Общепит

vsezip.ru

+7(812)987-08-81

MOD.	FREIDORAS	ZONA	PUERTAS				
ITEM	CODIGO	DENOMINACION	TEXTO	FG9-05	FG9-10	FE9-05	FE9-10
1	X162654000	CHAPA DOBLE PROTECCION		1	2	1	2
	Q419005000	REMACHE 4x8 ALMG3 / ALUMINIO		2	4	2	4
	Q152004000	TORN.APLASTADO M5x13 A 304		2	4	2	4
	Q221342000	REMACHE EXAGONAL M5		-	-	1	2
	Q152004000	TORN.APLASTADO M5x13 A 304		-	-	4	8
2	X162653000	CHAPA PROTECC. TERMOSTATO		1	2	1	2
3	X162669000	LISTON BISAGRA SUPERIOR DCH		1	1	1	1
S/N	X172602000	LISTON BISAGRA SUPERIOR IZDA		-	1	-	1
	Q221342000	REMACHE EXAGONAL M5		2	4	2	4
	Q221342000	REMACHE EXAGONAL M5		2	4	2	4
	Q221342000	REMACHE EXAGONAL M5		2	4	2	4
	Q152004000	TORN. APLASTADO M5x13 A 304		2	2	2	2
4	U020507000	ASA ARMARIO COMPLETA		1	2	1	2
	Q302022000	ARANDELA 16x6x1.2 A.304		2	2	2	2
	Q162040000	TUERCA EXAGONAL M6		2	4	2	4
5	U020502000	PUERTA LATERAL		1	2	1	2
5	U020513000	PUERTA LATERAL SUSPENDIDA		-	-	-	-
6	U020515000	REFUERZO PUERTA		1	2	1	2
6	U020515000	REFUERZO PUERTA SUSPENDIDA		-	-	-	-
	Q412000000	REMACHE TUBULAR 4x8		2	4	2	4
7	U020503000	CONTRAPUERTA LATERAL		1	2	1	2
7	U020514000	CONTRAPUERTA LATERAL SUSP.		-	-	-	-
	Q412000000	REMACHE TUBULAR 4x8		4	8	4	8
	Q419005000	REMACHE 4x8 ALMG3 / ALUMINIO		-	-	-	-
	Q419005000	REMACHE 4x8 ALMG3 / ALUMINIO		-	-	-	-



# Зип Общепит

vsezip.ru

+7(812)987-08-81

MOD.		FREIDORAS	ZONA	PUERTAS			
ITEM	CODIGO	DENOMINACION	TEXTO	FG9-05	FG9-10	FE9-05	FE9-10
8	U020511000	BISAGRA DERECHA INFERIOR		1	1	1	1
S/N	U020517000	BISAGRA IZQUIERDA INFERIOR			1		1
	Q302022000	ARANDELA 16x6x1.2 A.304		2	4	2	4
	Q012042000	TORNILLO EXAGONAL M6x15		2	4	2	4
	X960504000	TORNILLO DE GIRO M8		1	2	1	2
	Q232050000	ARANDELA A8		2	4	2	4
	Q232040000	ARANDELA A6		1	1	1	1
9	U020512000	ESC. REFUERZO BISAGRA DECH.		1	1	1	1
S/N	U020518000	ESC. REFUERZO BISAGRA IZDA.			1		1
	Q221343000	REMACHE EXAGONAL M6		1	2	1	2
	Q221342000	REMACHE EXAGONAL M5		2	4	2	4
	Q152004000	TORN.APLASTADO M5x13 A 304		2	4	2	4
10	X190504000	BISAGRA INFERIOR DECHA. SUSP.					
	Q152004000	TORN. APLASTADO M5x13 A 304					
11	X172603000	ESCUADRA AMARRE IMAN			1		1
	Q419005000	REMACHE 4x8 ALMG3 / ALUMINIO			2		2
12	X960501000	IMAN		2	4	2	4
13	X960502000	FIJACION IMAN		2	4	2	4
	Q012021000	TORNILLO EXAGONAL M4x10 A.304		2	4	2	4
	Q232020000	ARANDELA A-4		2	4	2	4

Зип Общелит

vsezip.ru

+7(812)987-08-81

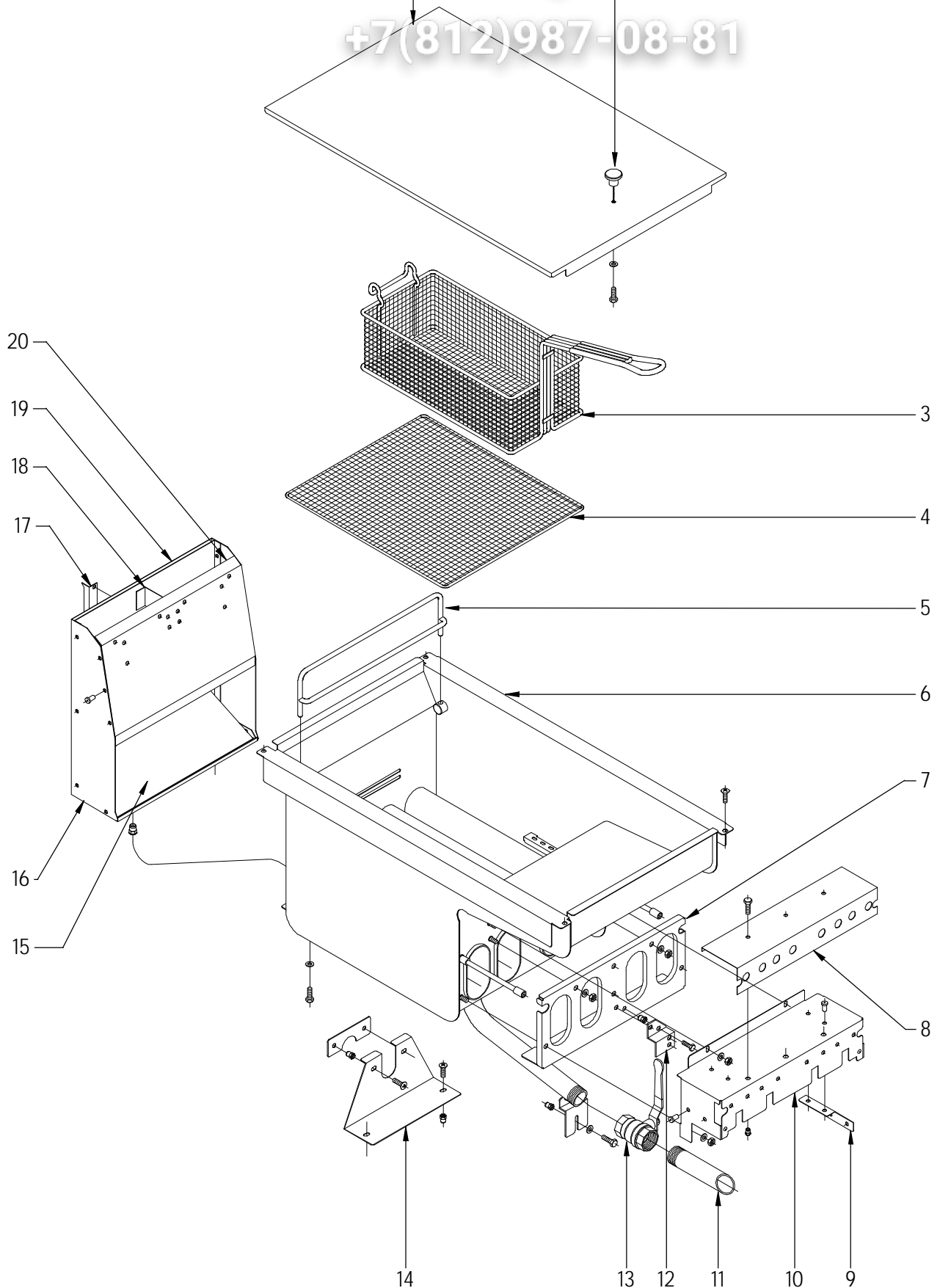

N plano

Firma

Fecha

Aparato

CUBA

Lamina

Fagor Industrial S.Coop.



C-1719

*Ирина Чернышова*

2006-06

FREIDORA GAMA 900

4

Onate

# Зип Общепит

vsezip.ru

+7(812)987-08-81

MOD.		FREIDORAS		ZONA	CUBA			
ITEM	CODIGO	DENOMINACION	TEXTO	FG9-05	FG9-10	FE9-05	FE9-10	
1	X166144000	TAPA DE CUBA		1	2			
1	X186113000	TAPA DE CUBA				1	2	
2	X166154000	POMO PARA TAPA		1	2	1	2	
	Q152004000	TORNIL. APLASTADO M5x13 A.304		2	2	2	2	
	Q302022000	ARANDELA 16x6x1,2 A.304		1	2	1	2	
3	X166525000	CESTILLO PEQUEÑO G900		2	4	2	4	
3	X166526000	CESTILLO GRANDE G900		1	2	1	2	
4	X166522000	REJILLA COMPLETA		1	2			
4	X186522000	REJILLA COMPLETA				1	2	
5	X166527000	SOPORTE COMPLETO CESTILLO		1	2	1	2	
6	X166146000	CUBA COMPLETA		1	2			
6	X186107000	CUBA COMPLETA ELECTRICA				1	2	
	Q012043000	TORNILLO EXAGONAL M6x20 A.304		1	2			
	Q302022000	ARANDELA 16x6x1.2 A.304		1	2			
	Q152004000	TORNIL. APLASTADO M5x13 A.304		4	8	4	8	
7	X162622000	PROTECCION FRENTE FG9-00		1	2			
	Q221342000	REMACHE EXAGONAL M5		3	6			
	Q012031000	TORNILLO EXAGONAL M5x10 A.304		3	4			
	Q162040000	TUERCA EXAGONAL M.6		10	20			
	Q232040000	ARANDELA A6		10	20			
8	X162673000	CAJA PROTECCION		1	2			
	Q419005000	REMACHE 4x8 ALMG3 / ALUMINIO		4	8			
9	X162676000	PROTEC. BULBO TERMOSTATO		2	4			
	Q419005000	REMACHE 4x8 ALMG3 / ALUMINIO		8	16			
	Q163040000	TUERCA EXAGONAL M6 LATON		2	4			
	Q302022000	ARANDELA 16x6x1,2 A.304		1	2			
	Q419005000	REMACHE 4x8 ALMG3 / ALUMINIO		2	4			
10	X162672000	CAJA DE QUEMADORES		1	2			
	Q221342000	REMACHE EXAGONAL M5		3	6			
	Q012031000	TORNILLO EXAGONAL M5x10 A.304		3	5			

# Зип Общепит

vsezip.ru

+7(812)987-08-81

MOD.	FREIDORAS	ZONA	CUBA				
ITEM	CODIGO	DENOMINACION	TEXTO	FG9-05	FG9-10	FE9-05	FE9-10
11	X166134000	TUBO SALIDA DE ACEITE		1	2	1	2
	Q221342000	REMACHE EXAGONAL M5		2	4	2	4
12	X162621000	SOPORTE PILOTO FG9-00		1	2		
13	X036107000	VAL. ESFERA PASO TOTAL 1		1	2	1	2
14	X182618000	SOPORTE TUBO DESAGUE				1	2
14	X182619000	SOPORTE TUBO DESAGUE					
	Q221342000	REMACHE EXAGONAL M5				4	8
	Q152004000	TORN.APLASTADO M5x13 A 304				4	8
	Q302022000	ARANDELA 16x6x1,2 A.304				1	2
	Q221342000	REMACHE EXAGONAL M5				2	4
15	X162660000	DEFLECTOR CHIMENEA		1	2		
	Q419005000	REMACHE 4x8 ALMG3 / ALUMINIO		2	4		
16	X162651000	LATERAL DE CHIMENEA		1	2		
17	U565611000	DISTANCI. DE CHIMENEA A PANEL		1	2		
	Q221343000	REMACHE EXAGONAL M6		2	4		
	Q012041000	TORNILLO EXAGONAL M6x10 A.304		2	4		
	Q302022000	ARANDELA 16x6x1,2 A.304		1	2		
	Q419005000	REMACHE 4x8 ALMG3 / ALUMINIO		7	14		
	Q419005000	REMACHE 4x8 ALMG3 / ALUMINIO		14	28		
	Q419005000	REMACHE 4x8 ALMG3 / ALUMINIO		3	6		
18	X162658000	DISTANCIADOR DE CHIMENEA		1	2		
	Q419005000	REMACHE 4x8 ALMG3 / ALUMINIO		2	4		
	Q152004000	TORN.APLASTADO M5x13 A 304		2	4		
	Q221342000	REMACHE EXAGONAL M5		2	4		
19	X162652000	POSTERIOR DE CHIMENEA		1	2		
20	X162650000	ANTERIOR DE CHIMENEA		1	2		

Зип Общежит

vsezip.ru

+7(812)987-08-81

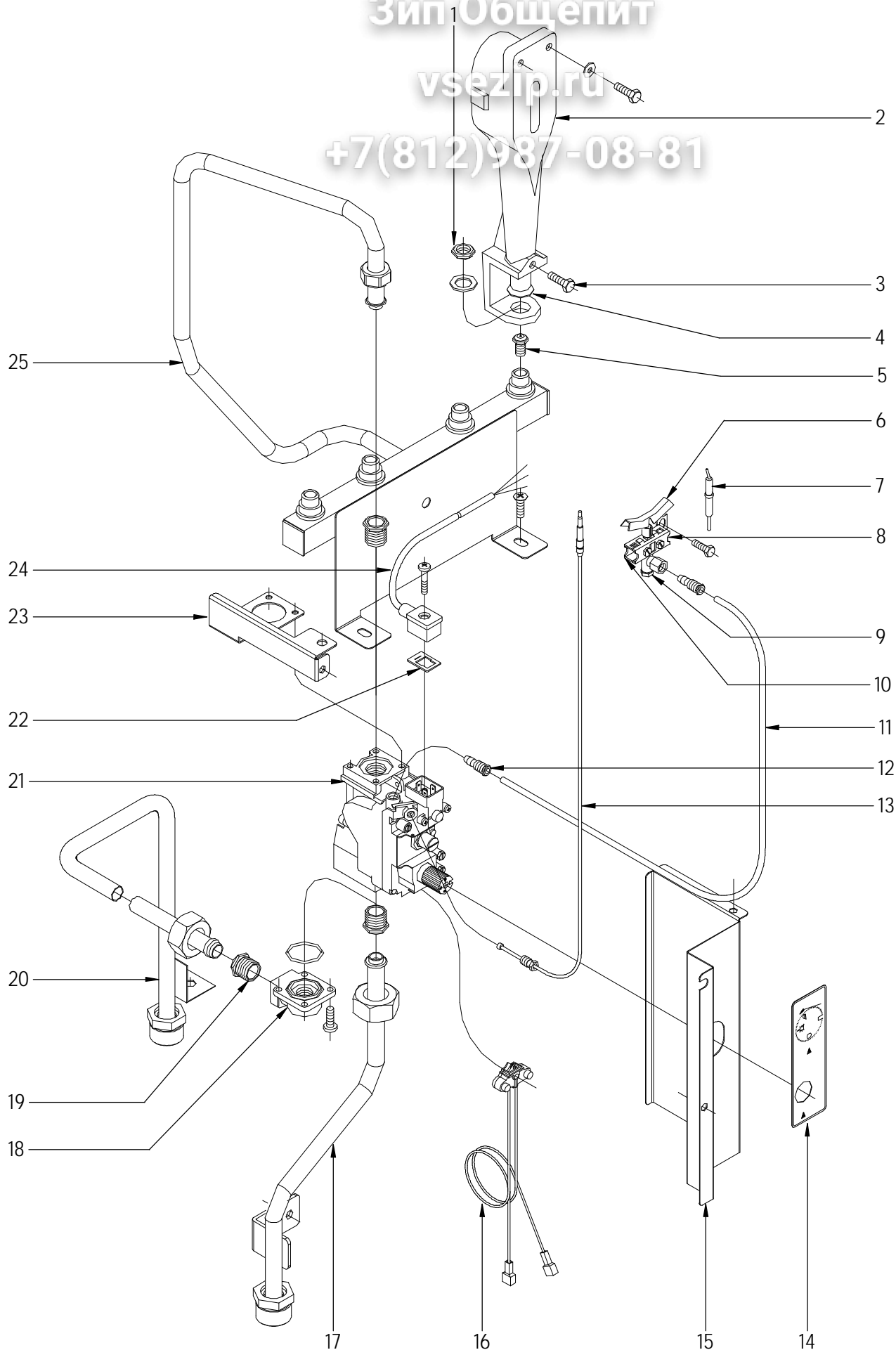

N plano	Firma	Fecha	Aparato	PARTE FUNCIONAL GAS	Lamina	Fagor Industrial S.Coop. <b>FAGOR</b>
C-1720	name (signature)	2006-05	FREIDORA GAMA 900		5	Onate

# Зип Общепит

vsezip.ru

+7(812)987-08-81

MOD.		FREIDORAS	ZONA	PARTE FUNCIONAL GAS			
ITEM	CODIGO	DENOMINACION	TEXTO	FG9-05	FG9-10	FG9-05S	
1	Q223021000	TUERCA EXAGONAL 15x1		4	8	4	
2	X015700000	QUEMADOR COMPLETO FG9-00		4	8	4	
3	Q012043000	TORNILLO EXAGONAL M6x20 A.304		8	16	8	
	Q302022000	ARANDELA 16x6x1,2 A.304		1	1	1	
	Q301322000	ARANDELA PLANA 27x17x2		4	8	4	
	Q012043000	TORNILLO EXAGONAL M6x20 A.304		4	8	4	
4	U325707000	REGULADOR DE AIRE		4	8	4	
5	X162403000	TOBERA Ø 1,25 (BUTANO-PROP.)		4	8	4	
5	9429400000	TOBERA Ø 1,80 (GAS NATURAL)		4	8	4	
6	X012117000	PILOTO		1	2	1	
	Q012031000	TORNILLO EXAGONAL M5x10 A.304		2	4	2	
S/N	X012122000	REGULADOR DE AIRE 912.001		1	2	1	
7	X012101000	BUJIA 915.037		1	2	1	
8	X012114000	AMARRE DELANT. PILOTO 978.004		1	2	1	
9	X012126000	CUERPO PILOTO 901.210		1	2	1	
S/N	U442138000	INYECTOR Ø 0.25 (BUTANO-PROP.)		1	2	1	
S/N	U442137000	INYECTOR Ø 0.4 (GAS NATURAL)		1	2	1	
10	X012113000	AMARRE TRAS. PILOTO 978.003		1	2	1	
	X012116000	TORNILLO AMARRE PILOTO		2	4	2	
11	X165058000	TUBO PILOTO GAMA 900		1	2	1	
12	U134323000	RACORD BICONO 6 958.031		2	4	2	
13	U562130000	TERMOPAR L=850		1	2	1	
14	X162617000	PEGATINA POSICION MANDO		1	2	1	
15	X162615000	PROTECCION ELECTROVALVULA		1	2	1	
	X723014000	PASAMUROS Ø30		1	2	1	
	Q152004000	TORN.APLASTADO M5x13 A 304		2	4	2	
	Q221342000	REMACHE EXAGONAL M5		1	2	2	
16	R275027000	CABLEADO ELECTROSIT 927.012		1	2	1	

# Зип Общепит

vsezip.ru

+7(812)987-08-81

MOD.		FREIDORAS		ZONA	PARTE FUNCIONAL GAS		
ITEM	CODIGO	DENOMINACION	TEXTO	FG9-05	FG9-10	FG9-05S	
17	X165062000	ENTRADA GENERAL COMPLETA		1	2		
	Q152004000	TORN.APLASTADO M5x13 A 304		2	4		
	Q221342000	REMACHE EXAGONAL M5		1	2		
	Q221342000	REMACHE EXAGONAL M5		2	4		
	Q221342000	REMACHE EXAGONAL M5		2	4		
	Q306013000	ARANDELA PLANA 30,4x22,4x3		1	2		
	Q162040000	TUERCA EXAGONAL M6		2	4		
	Q302022000	ARANDELA 16x6x1,2 A.304		1	1		
18	X153004000	CODO 1-2 820NOV 906.260				1	
19	S205023000	MANGUITO DOBLE 1/2		2	4	2	
	Q306057000	ARANDELA 18x12,5 x1,5		2	4	2	
20	X195055000	ENTRADA GENERAL COMPLETA				1	
	Q306013000	ARANDELA PLANA 30,4x22,4x3				1	
	Q162040000	TUERCA EXAGONAL M6				2	
	Q302022000	ARANDELA 16x6x1,2 A.304				1	
	Q221342000	REMACHE EXAGONAL M5				1	
21	X163000000	ELECTROVALVULA NOVA 820.018		1	2	1	
22	X163009000	JUNTA CONECTOR NOVA 960.104		1	2	1	
23	X162629000	SOPORTE VALVULA		1	2	1	
	Q152004000	TORN.APLASTADO M5x13 A 304		5	10	5	
	Q221343000	REMACHE EXAGONAL M6		1	2	1	
24	X163008000	CABLE CONECTOR 820 960.103		1	2	1	
25	X165060000	TUBO DISTRIBUIDOR FG9-00		1	2		
25	X195053000	TUBO DISTRIBUIDOR FG9-05S				1	
	Q306013000	ARANDELA PLANA 30,4x22,4x3		1	2	1	
	Q152004000	TORN.APLASTADO M5x13 A 304		2	4	2	
	Q221343000	REMACHE EXAGONAL M6		1	2	1	
	Q152004000	TORN.APLASTADO M5x13 A 304				2	

Зип Общепит

vsezip.ru

+7(812)987-08-81

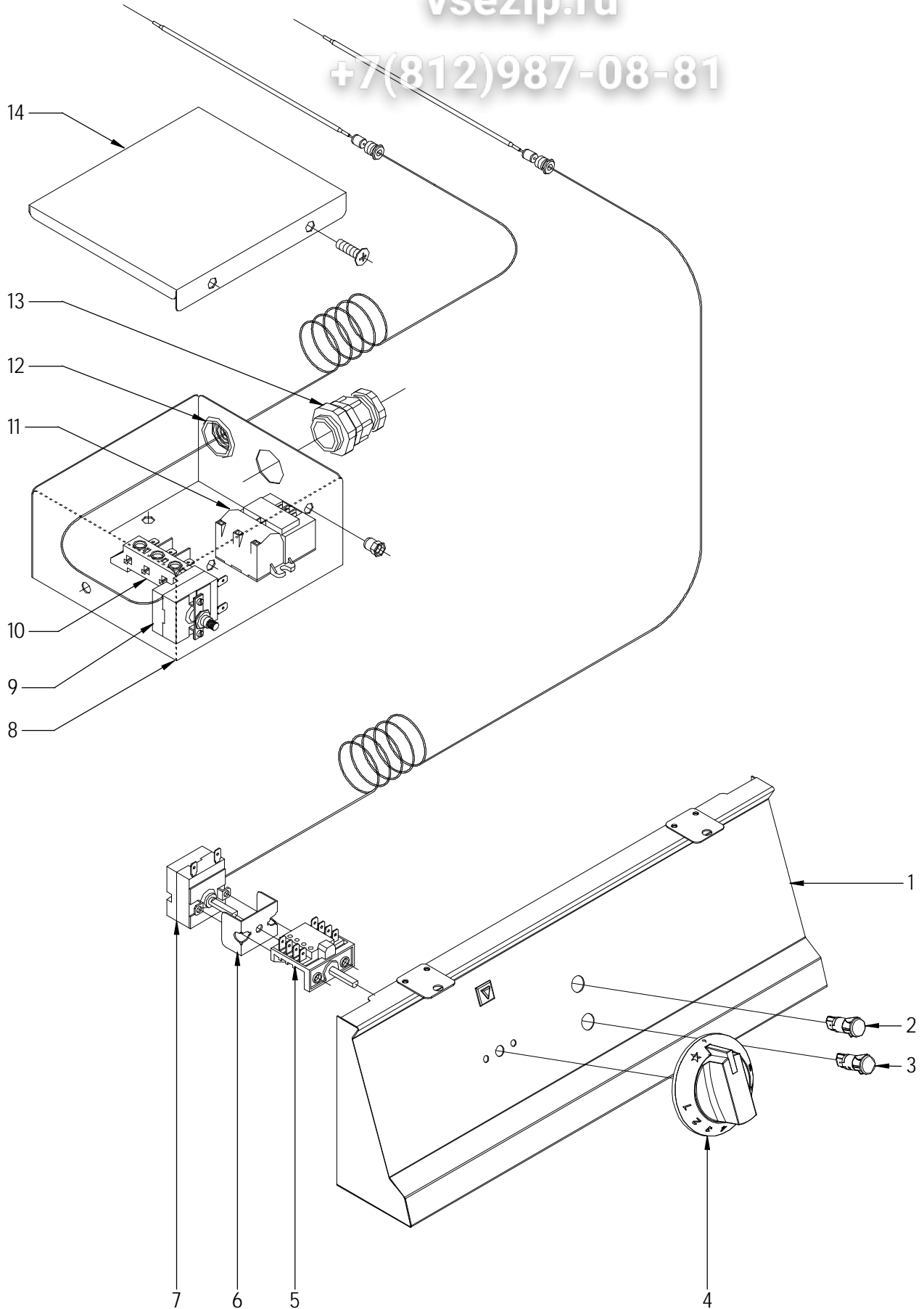

N plano

C-1721

Firma

*[Signature]*

Fecha

2006-06

Aparato

FREIDORA GAS GAMA 900

PARTE FUNCIONAL ELECTRICA

Lamina

6

Fagor Industrial S.Coop.

Onate

**FAGOR** 



# Зип Общепит

vsezip.ru

+7(812)987-08-81

MOD.	FREIDORAS A GAS	ZONA	PARTE FUNCIONAL ELECTRICA				
ITEM	CODIGO	DENOMINACION	TEXTO	FG9-05	FG9-10	FG9-05S	
1	X502805000	PORTAM. COMP. FREIDORA 1/2M		1		1	
1	X702801000	PORTAM. COMP. FREIDORA 1M			1		
	Q419005000	REMACHE 4x8 ALMG3 / ALUMINIO		2	4	2	
	Q523000000	TERMINAL LENGÜETA 6,35		1	1	1	
2	R693055000	PILOTO VERDE 41227000C7		1	2	1	
3	R693056000	PILOTO AMBAR		1	2	1	
4	X503005000	MANDO MONTADO FREID.GAS Ø6		1	2	1	
5	X163007000	CONMUTADOR ACOUPLE TERMOST.		1	2	1	
6	X313001000	U SOPORTE TERMOSTATO		1	2	1	
	Q151320000	TORNILLO ALOMADO M4x6 H,ZINC.		2	4	2	
7	X163010000	TERMOSTATO		1	2	1	
8	X163022000	CUADRO ELECTRICO FG9-00		1	2		
8	X193000000	CUADRO ELECTRICO FG9-00S				1	
	Q012042000	TORNILLO EXAGONAL M6x15		2	2	2	
9	X163001000	TERMOSTATO LIMITADOR		1	2	1	
	Q151320000	TORNILLO ALOMADO M4x6 H,ZINC.		2	4	2	
10	U183046000	REGLETA AUXILIAR		1	2	1	
	Q152004000	TORNILLO APLAST, M5x13 A304		2	4	2	
11	R073007000	ENCENDEDOR 2 BUJIAS		1	2	1	
	Q302022000	ARANDELA 16x6x1,2 A.304		1	2	1	
	Q152004000	TORNILLO APLAST, M5x13 A304		2	4	2	
12	X723014000	PASAMUROS Ø30		1	2	1	
13	R023013000	PRENSA ESTOPAS		1	2	1	
	R023025000	CONTRATUERCA GAES		1	2	1	
	R023026000	JUNTA DE GOMA GAES		1	2	1	

# Зип Общепит

vsezip.ru

+7(812)987-08-81

MOD.	FREIDORAS A GAS			ZONA	PARTE FUNCIONAL ELECTRICA			
ITEM	CODIGO	DENOMINACION	TEXTO	FG9-05	FG9-10	FG9-05S		
14	X163023000	TAPA CUADRO ELECTRICO		1	2			
14	X193001000	TAPA CUADRO ELECTRICO				1		
	Q221342000	REMACHE EXAGONAL M5		6	12			
	Q152004000	TORNILLO APLAST, M5x13 A304		6	12			
	Q152004000	TORNILLO APLAST, M5x13 A304		3				
	Q221342000	REMACHE EXAGONAL M5		3		2		
	Q162030000	TUERCA EXAGONAL M5				1		
	Q302022000	ARANDELA 16x6x1,2 A.304				1		
	Q012032000	TORNILLO EXAGONAL M5x15 A304				2		
	Q221342000	REMACHE EXAGONAL M5				4		

Зип Общепит

sezip.ru

+7(812)987-08-81

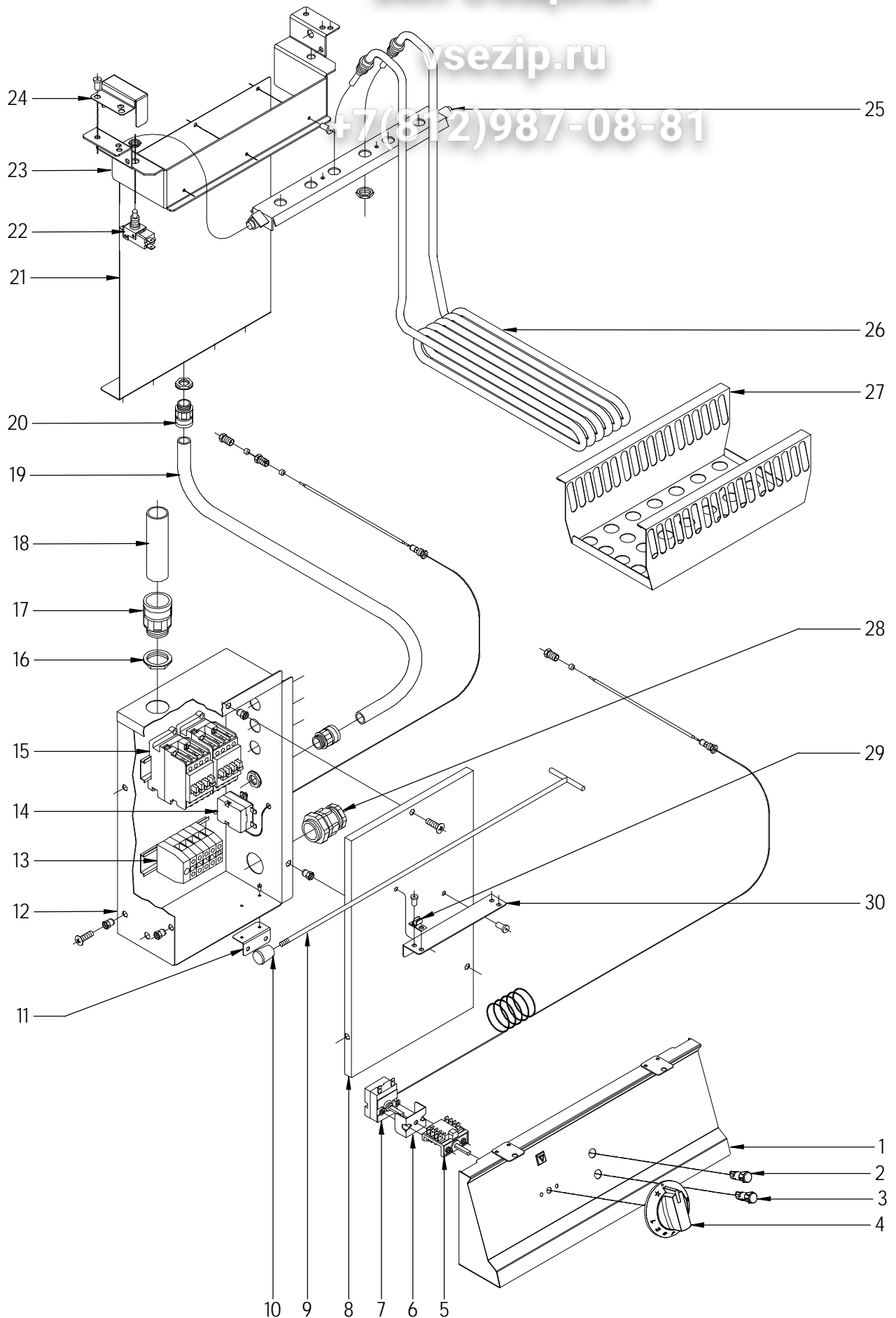

N plano	Firma	Fecha	Aparato	PARTE FUNCIONAL ELECTRICA	Lamina	Fagor Industrial S.Coop. <b>FAGOR</b>
C-1722	<i>[Signature]</i>	2006-06	FREIDORA ELECTRICA G-900	7	Onate	

# Зип Общепит

vsezip.ru

+7(812)987-08-81

MOD.		FREIDORAS ELECTRICAS		ZONA	PARTE FUNCIONAL ELECTRICAS		
ITEM	CODIGO	DENOMINACION	TEXTO	FE9-05	FE9-10	FE9-05S	
1	X502805000	PORTAM. COMP. FREIDORA 1/2M		1		1	
1	X702801000	PORTAM. COMP. FREIDORA 1M			1		
	Q419005000	REMACHE 4x8 ALMG3 / ALUMINIO		2	4	2	
	Q523000000	TERMINAL LENGÜETA 6,35		1	1	1	
2	R693055000	PILOTO VERDE 41227000C7		1	2	1	
3	R693056000	PILOTO AMBAR		1	2	1	
4	X183064000	MANDO FREIDORA ELECTRICA Ø6		1	2	1	
5	X163007000	CONMUTADOR ACOUPLE TERMOST.		1	2	1	
6	X313001000	U SOPORTE TERMOSTATO		1	2	1	
	Q151320000	TORNILLO ALOMADO M4x6 H,ZINC.		2	4	2	
7	X163010000	TERMOSTATO		1	2	1	
8	X183053000	TAPA CUADRO ELECTRICO		1	2		
8	X233001000	TAPA CUADRO ELECTRICO				1	
	Q152004000	TORNILLO APLAST, M5x13 A304		3	6	3	
9	X183056000	GANCHO SOPOR. RESISTENCIAS		1	2	1	
10	X183057000	POMO M6 (ELESA-REF.23901)		1	2	1	
11	X183052000	ESC. AMARRE CUADRO ELECTRIC		1	1		
S/N	X713002000	ESC. AMARRE INFERIOR CUADRO			1		
	Q419005000	REMACHE 4x8 ALMG3 / ALUMINIO		2	4		
	Q221342000	REMACHE EXAGONAL M5		3	6		
	Q221342000	REMACHE EXAGONAL M5		3	6		
	Q152004000	TORNILLO APLAST, M5x13 A304			2		
12	X183051000	CUADRO ELECTRICO		1	1		
12	X713001000	CUADRO ELECTRICO			1		
12	X233000000	CUADRO ELECTRICO				1	
	Q162030000	TUERCA EXAGONAL M5				3	
	Q302022000	ARANDELA 16x6x1,2 A.304				3	

# Зип Общепит

vsezip.ru

+7(812)987-08-81

MOD.	FREIDORAS ELECTRICAS	ZONA	PARTE FUNCIONAL ELECTRICA				
ITEM	CODIGO	DENOMINACION	TEXTO	FE9-05	FE9-10	FE9-05S	
13	Z683069000	BORNA16		3	6	3	
	Z683097000	BORNA WDU16 10204.8		1	2	1	
	Z683070000	BORNA TIERRA WEIDMULLER		1	2	1	
	Z683096000	TOPE FINAL WEW35 10590.0		1	2	1	
	Z683068000	SEÑALIZ.DEK-6 WEIDMULLER		1	2	1	
14	R663055000	GUIA CONTACTOR L-120		1	2	1	
	Q419005000	REMACHE 4x8 ALMG3 / ALUMINIO		2	4	2	
	X163001000	TERMOSTATO LIMITADOR		1	2	1	
	Q151320000	TORNILLO ALOMADO M4x6 H,ZINC.		2	4	2	
	X183011000	CONTAC. 3RT1024-1AN20 230V50H		2	4	2	
15	R663055000	GUIA CONTACTOR L-120		1	2	1	
	Q419005000	REMACHE 4x8 ALMG3 / ALUMINIO		2	4	2	
	R023025000	CONTRATUERCA GAES		1	2	1	
	X713021000	RACORD ICK 5020		1	2	1	
	3712300000	TUBO PG 21 0233.204.023		1	2	1	
16	Q222005000	TUERCA EXAGONAL M10x0,75		1	2	1	
	3712600000	TUBO PG 11 0233.204.012		4	8	4	
	X033027000	RACORD QUICK 5020.049.011		8	16	8	
	X033028000	CONTRATUERCA 790.1100.0		8	16	8	
	X182635000	SUPLEMENTO GUIA CABLES		1	2	1	
21	Q221342000	REMACHE EXAGONAL M5		2	4	2	
	X343015000	MICRORRUPTOR COD.32280001		1	2	1	
	Q222005000	TUERCA EXAGONAL M10x0,75		1	2	1	
	Q306055000	ARANDELA 16x10,3x1		1	2	1	
	Q161310000	TUERCA EXAGONAL M3 H.ZINCADA		10	20	10	
23	X182634000	SOPORTE GIRO RESISTENCIAS		1	2	1	
	X182640000	PROTECCION MICRORRUPTOR		1	2	1	
24	Q221342000	REMACHE EXAGONAL M5		6	12	6	
	X182633000	GIRO RESISTENCIAS COMPLETO		1	2	1	
	Q221342000	REMACHE EXAGONAL M5		1	2	1	
25	Q152004000	TORNILLO APLAST, M5x13 A304		2	4	2	

# Зип Общепит

vsezip.ru

+7(812)987-08-81

<b>MOD.</b>	<b>FREIDORAS ELECTRICAS</b>	<b>ZONA</b>	<b>PARTE FUNCIONAL ELECTRICA</b>				
ITEM	CODIGO	DENOMINACION	TEXTO	FE9-05	FE9-10	FE9-05S	
26	X183068000	RESISTENCIA 6 KW		3	6	3	
27	X183023000	CHAPA FIJACION RESISTENCIAS		1	2	1	
28	R023013000	PRENSA ESTOPAS		1	2	1	
	R023025000	CONTRATUERCA GAES		1	2	1	
	R023026000	JUNTA DE GOMA GAES		1	2	1	
29	X183055000	PINZA JEBE 6-7		2	4	2	
	Q419006000	REM.TUBULAR C/VASTAGO 3,2x10		4	8	4	
30	X183054000	ESCUADRA SOPORTE GANCHO		1	2	1	
	Q419005000	REMACHE 4x8 ALMG3 / ALUMINIO		2	4	2	

# Зип Общепит

vsezip.ru

+7(812)987-08-81

MOD.	FREIDORAS			VARIOS				
	ITEM	CODIGO	DENOMINACION	TEXTO	FG9-05	FG9-10	FG9-05S	FE9-05
	X166521000	FOLLETO DE INSTRUCC.	FG9-00		1	1	1	
	X186550000	FOLLETO DE INSTRUCC.	FE9-00					1
	X163018000	CABLEADO PORTAMANDOS			1	2	1	
	X183060000	CABLEADO PORTAMANDOS						1
	U323007000	CABLE ENCENDEDOR A BUJIA			1	2	1	
	X163002000	CABLE BUJIA			1	2	1	
	X183008000	CABLEADO REGLETA A CONTACT.						2
	X183009000	CABLEADO MICRO						1
	X183066000	CABLEADO RESISTENCIAS						3
	X163005000	ESQUEMA TEORICO ADHESIVO			1	1	1	
	X183059000	ESQUEMA TEORICO ADHESIVO						1

# Зип Общепит

vsezip.ru

+7(812)987-08-81

MOD.	FREIDORAS	ZONA	PIEZAS ESPECIFICAS PARA LOS DIST GASES			
ITEM	CODIGO	DENOMINACION	TEXTO	FG9-05	FG9-10	FG9-05S
		<u>BUTANO - PROPANO</u>				
5	X162403000	TOBERA Ø 1,25		4	8	4
9	U442138000	INYECTOR Ø 0.25		1	2	1
S/N	U136501000	INDICADOR BUTANO-PROPANO		1	1	1
		<u>GAS NATURAL</u>				
5	9429400000	TOBERA Ø 1,80		4	8	4
9	U442137000	INYECTOR Ø 0.4		1	2	1
S/N	U134402000	INDICADOR GAS NATURAL		1	1	1